

# Sea Recovery Aqua Matic

Mid to Mega Yachts  
(40 - over 80 ft / 12 - over 24 m)



## Tomorrow's Technology, Here Today

The Aqua Matic watermaker features automatic operation with a touchscreen control panel that allows simple touch-and-go operations. Product water quality is now displayed in a bar graph format. Regulation and monitor systems function without the need of an operator. Sea Recovery's high-pressure design includes double O-ring seals on duplex stainless steel fittings to ensure leak-proof operation.



Aqua Matic - compact

## Contact Information:

Parker Hannifin Corporation  
**Water Purification**  
2630 E. El Presidio Street  
Carson, CA 90810

**phone 310 608 5600**  
**fax 310 608 5692**  
**waterpurification@parker.com**

**Website:**  
[www.parker.com/waterpurification](http://www.parker.com/waterpurification)

**Sales:**  
[waterpurification@parker.com](mailto:waterpurification@parker.com)

**Tech Support:**  
[watertech@parker.com](mailto:watertech@parker.com)

## Features & Benefits:

- An automated screen informs the operator of required maintenance
- Available in a small footprint, compact frame for easy installation
- Full color, touchscreen remote control
- Ability to display in multiple languages



Touchscreen Controller



Aqua Matic - modular



ENGINEERING YOUR SUCCESS.

# Specifications

	Model #	Production / Hr.	Production / 24 hrs.	AQM Compact*	AQM Modular*
<b>PRODUCTION &amp; WEIGHT</b>	450-1	19 Gal / 71 L	450 Gal / 1,703 L	153 lbs / 69 kg	149 lbs / 68 kg
	700-1	29 Gal / 110 L	700 Gal / 2,650 L	156 lbs / 71 kg	152 lbs / 69 kg
	900-1	38 Gal / 142 L	900 Gal / 3,407 L	158 lbs / 72 kg	154 lbs / 70 kg
	900-2	38 Gal / 142 L	900 Gal / 3,407 L	165 lbs / 75 kg	161 lbs / 73 kg
	1400-2	58 Gal / 221 L	1,400 Gal / 5,300 L	171 lbs / 76 kg	167 lbs / 76 kg
	1800-2	75 Gal / 284 L	1,800 Gal / 6,814 L	176 lbs / 80 kg	172 lbs / 78 kg

ELECTRICAL	Phase	Pump Motor	Voltage VAC	Hz	NOA	SUC	Operating Voltage	Start Up Current
<b>Plunger Pump Radial Axial Pump</b>					<b>110 / 220</b>	<b>110 / 220</b>		
	Single	HP / Booster	110-115 / 220 -230	50 / 60	30 / 15	100 / 50	110-115 / 220-230	40 Ampere / 20 Ampere
	Single	HP / Booster	110-115 / 220 -230	50 / 60	35 / 17.5	100 / 55	110-115 / 220-230	45 Ampere / 25 Ampere
	Three	HP / Booster	220-230 / 380-460	50 / 60	11 / 5.5	30 / 15	220 / 380 / 460	15 Ampere / 10 Ampere / 10 Ampere
	Three	HP / Booster	220-230 / 380-460	50 / 60	11 / 5.5	30 / 15	220 / 380 / 460	15 Ampere / 10 Ampere / 10 Ampere

\*Production may vary +/-20% | GPD: Gallons per day • LPD: Liters per day

## Dimensions

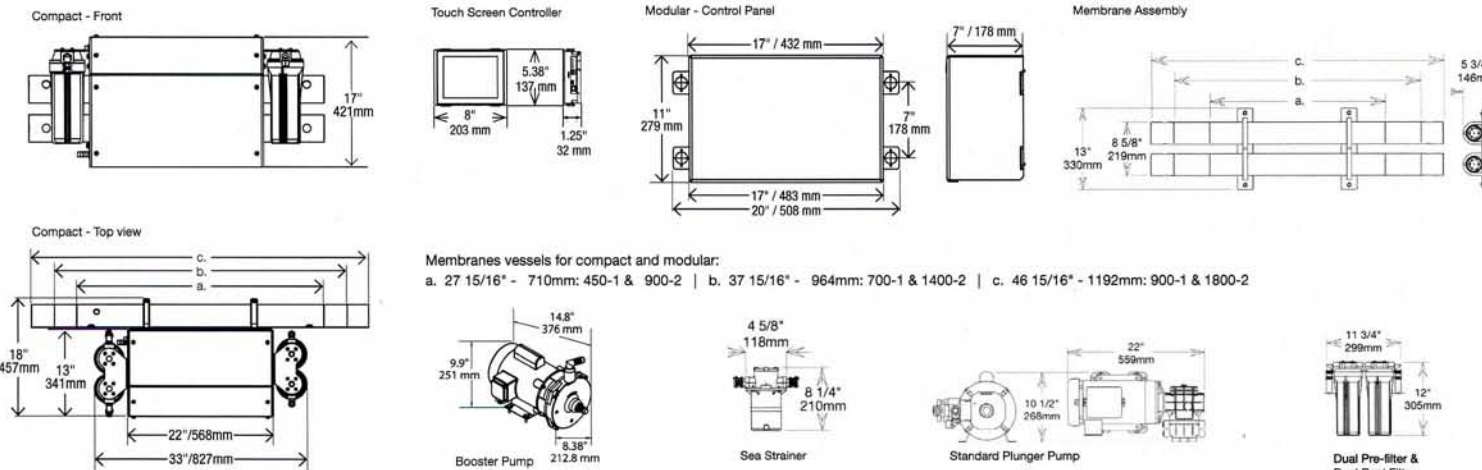

**WARNING:** This product can expose you to chemicals including Di(2-ethylhexyl) phthalate (DEHP), which is known to the state of California to cause cancer and birth defects or other reproductive harm. For more information go to [www.P65Warnings.ca.gov](http://www.P65Warnings.ca.gov).